



Turbocharger Testing

using the LogBook/300

Automotive

Application Note #41

Turbochargers are one of many products manufactured in the war against pollution. Automotive manufacturers, government agencies, and environmental organizations concerned with pollution from automobile and truck exhaust rely on turbochargers to reduce harmful emissions by increasing air intake to a vehicle's engine. To verify that vehicles equipped with turbochargers meet these requirements, on- and off-road testing is required.

Application Summary

A leading manufacturer of turbochargers and other anti-pollution products must verify that their electronically activated turbocharger (called a "supercharger") more effectively reduces harmful emissions by activating faster than other turbocharger products. The manufacturer's supercharger mounts in the vehicle's intake line; when pressure is applied to the pedal, a trigger switch causes the supercharger's built-in wheel to spin immediately, generating pressure to the intake, thereby improving fuel burn, engine power, and a reduction in emissions. The elimination of this lag time — normally spent waiting for a turbocharger's wheel to spin up to speed and generate pressure to the intake — leads to the supercharger's superiority.

The engineers test their supercharger in a two-part investigation. First it is tested on a laboratory dynamometer, where the supercharger is installed into a typical vehicle and measured for current, engine rpm, manifold pressure, motor speed, horsepower, and torque. Later, the vehicle is removed from the lab and taken on a road test where the same parameters are measured under normal driving conditions. Engineers directly compare the supercharged vehicle's performance results to the same vehicle operating with the supercharger turned off.

The researchers needed a PC-based data acquisition system to monitor, record, and analyze their supercharger's performance. To be effective, the data acquisition system has to be mobile, powered by the vehicle battery, and withstand the vibration associated with road testing.

IOtech's Solution

The manufacturer evaluated a number of systems, and selected IOtech's **LogBook/300™** stand-alone data acquisition system. Their research required storage of 10-Mbyte data files that were too large for the typical memory sizes available with comparably priced data acquisition systems.

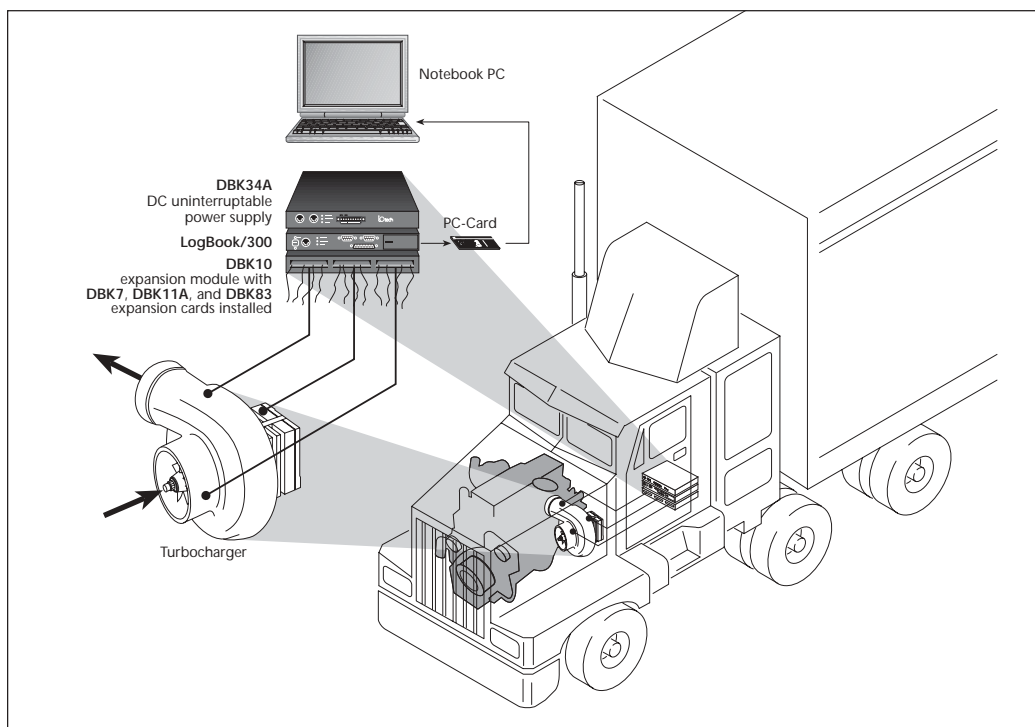

The manufacturer was impressed with the data acquisition system's capability to store large data files generated by their research. The **LogBook/300** uses removable PC-Card memory (PCMCIA), allowing researchers to use a 20-Mbyte memory storage PC-Card. More importantly, the manufacturer liked the system's signal conditioning options and included **LogView™ Out-of-the-Box™** graphical data acquisition software, which gave them the ability to view real-time data with no programming required.

The engineers also appreciated the **LogBook/300's** compact size (11" x 8.5" x 1.75"), the same form factor as a notebook PC, which allowed the system to fit easily under the front seat of the test vehicle.

Monitoring key parameters in and around the turbocharger allows engineers to assess the performance of the design.



The researchers measured current, engine rpm, manifold pressure, motor speed, horsepower, and torque by way of sensors installed on the engine and wired to the data acquisition system located inside the vehicle. All connections were zip tied and secured with epoxy to avoid contact with moving parts.

Several signal conditioning options expanded the capability of the LogBook/300 system: IOtech's DBK7™ frequency input card provided 4 channels of frequency measurement capability; the DBK83™ thermocouple input card provided 14 channels of highly accurate thermocouple measurements plus automatic cold-junction compensation; the DBK11A™ provided researchers with convenient screw terminals for signal connection; and the DBK34A™ provided backup power to the LogBook/300 system in case the vehicle's battery voltage dropped.

After each test was completed, engineers removed the PC-Card from the LogBook/300, inserted it into a laptop computer, and reviewed the data with included eZ-PostView™ software, a post-acquisition viewing package included with LogView™ software. Using eZ-PostView™, the engineers were able to display and scroll data from files that were too large to evaluate using Microsoft Excel.

Conclusion

Mobile and easy to use, the Logbook/300 data acquisition system from IOtech provides a high-performance solution to researchers testing in the lab and in the field. The system's extensive signal conditioning options make it an effective solution that outperforms other groups of test and measurement instruments in its price range. With nonvolatile storage of up to 250 million samples via removable PC-Card memory, the Logbook/300 is a compact solution for portable data collection that makes it an effective alternative to more expensive stand-alone data acquisition systems.

LogBook/300



IOtech's LogBook/300™ data acquisition system provides highspeed, low cost, and ease-of-use, without requiring a PC at your test site. The intelligent LogBook/300 executes your data acquisition applications and saves acquired data using low-cost PC-Card memory. And since you don't need a PC at the test site, you save cost, space, and avoid the threat of damage or theft to your PC.

Features

- 16-bit, 100-kHz A/D converter with digital calibration
- 16-channel analog inputs — expandable up to 256 channels
- Digital I/O, frequency I/O, and analog output expandable to over 200 channels
- Non-volatile storage of up to 250 million samples via low-cost and removable PC-Card memory
- Infinite acquisition duration by swapping PC-Cards
- Direct communication with PC via serial, parallel port, or modem if desired
- Optional control terminal for triggering & reviewing acquired data
- Signal conditioning options for strain gages, thermocouples, accelerometers, and nearly every other signal type
- AC or DC powerable
- Vehicle network interface option
- GPS option

Signal Conditioning Options

- Expansion cards and modules for high-voltage/current, strain gages, thermo-couples, isolation, relays, accelerometers, filtering, simultaneous sample & hold, vehicle network measurements, and more



LogView requires no programming or block diagram configuration

Software

- Includes LogView™ Out-of-the-Box™ software for easy setup, calibration, and more; no programming required
- Simple spreadsheet-style interface provides powerful setup features for immediate startup
- Acquisition configurations can be transported to the LogBook via PC-Card, serial port, parallel port, or modem connection
- Provides direct support for a wide variety of transducers
- Includes eZ-PostView™ for post-acquisition data viewing

DBK34A™, DBK84™, eZ-PostView™, LogBook™, LogView™, and Out-of-the-Box™ are the property of IOtech; all other trademarks and tradenames are the property of their respective holders.