



Video Signal Alarm Monitoring using the Personal Daq/56

TV Broadcast Industry

Application Note #55

Application Summary

During the early years of television broadcasting, video production and distribution consisted primarily of moving the video signal from the camera where it was created to the transmitter where it was broadcast. Monitors connected to each camera were installed in the control room to help operators select the camera angle, and a few other monitors displayed the health of the video image before transmission. Technicians also checked oscilloscope displays of the composite video signal to ensure that it met NTSC standards.

Today, however, video signals are distributed over wider areas and go through much more processing than this. The signals are not only generated by cameras, but are often synthesized, manipulated, recorded, and re-recorded. Also, the signals are both analog and digital, so processing includes distributing the video signal over many more channels with more opportunities for failures along the way. Monitoring the health of these video signals requires an automatic system that lets technicians go about their daily tasks without constantly watching a monitor. Some highly sophisticated and dedicated diagnostic systems are available to do the job, but

they are very expensive which forces some distribution amplifier manufacturers to look for less pricey, but reliable alternative solutions.

IOtech's Solution

One such company, PatchAmp Corp., Hackensack, N.J., came up with a novel approach using IOtech **Personal Daq/56**™ modules. The modules comprise a data acquisition system with USB connections hubbed to a central computer. They also contain analog and digital signal inputs for signal processing, recording, and alarming. PatchAmp builds video distribution amplifiers for numerous applications in studios, TV stations, and remote locations. It must ensure complete signal reliability, nearly 100% up-time, which is not an easy task.

The company uses **Personal Daq/56** modules, about the size of a Palm Pilot, and **DASYLab**® software to look for several types of common video failures, including frozen images, lost video signals, or completely black, green, or blue screens. The signals don't require a high bandwidth, so PatchAmp converts all digital signals to an analog representation, and then rectifies the signal to obtain a varying DC voltage. Under the direction of built-

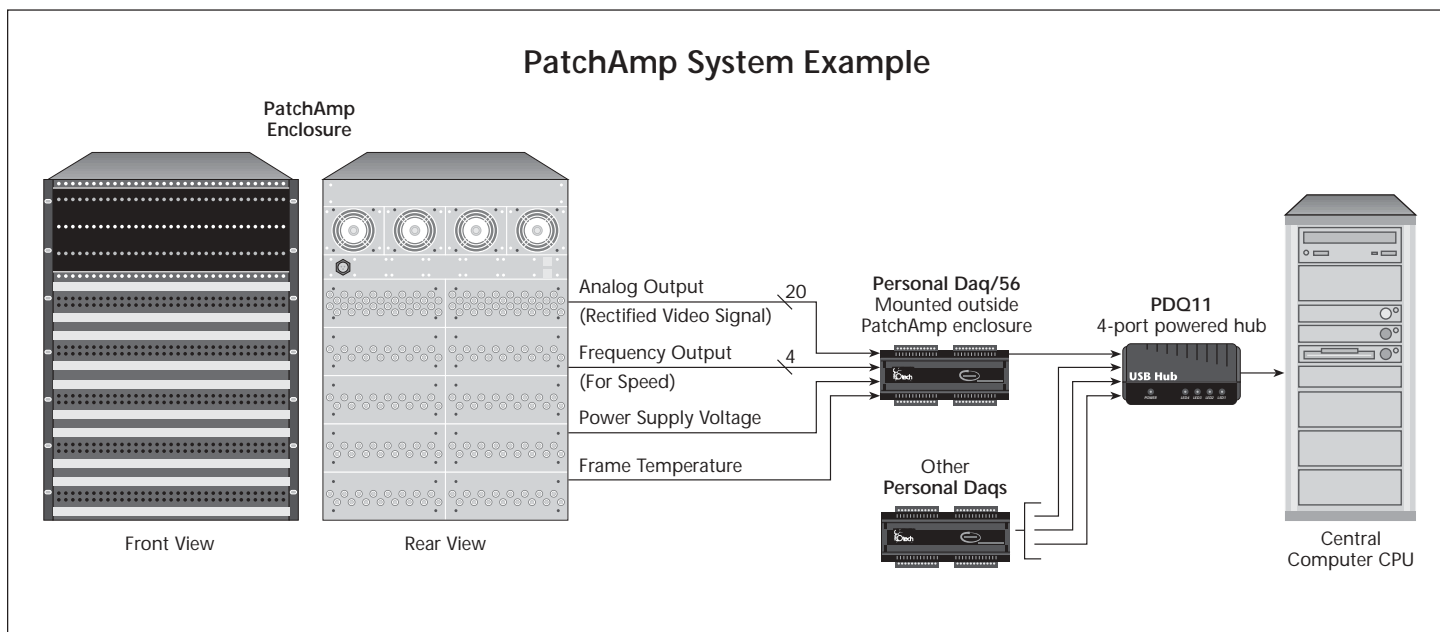

The largest PatchAmp frame contains 32 video distribution amplifiers and two power supplies for redundancy. The **Personal Daq/56** with custom algorithms are an inexpensive, flexible, simple, and reliable means for detecting soft failures in the critical path of a video stream passing through the amplifiers such as frozen, lost, or single-color pictures. But because some customers don't need an alarm system, PatchAmp doesn't have to include a fault detection microprocessor on each amplifier board: The **Personal Daq/56** provides the alarm to satisfy only those that need it.



in proprietary algorithms, the system analyzes the voltage and identifies each type of failure. The equipment is programmed to alarm each failure, and it directs technicians to the faulted rack instead of letting them search the entire site, which often hosts 100 or more individual channels.

Another type of fault is a hardware failure. Here, the failure is called a summing fault, detected by hardwired circuitry built onto the distribution amplifier card. These faults are activated when a card “dies,” or starts drawing excessive current if the air conditioning fails. Other hard faults such as lost signals and improper data are also summed together and trigger an alarm. But a frozen or black picture, for example, is not a part of the summary fault, so the [Personal Daq/56](#) detects it.

One IOtech [Personal Daq/56](#) data acquisition system connects to either a 24 or 32-channel PatchAmp distribution amplifier or one chassis. Often, however, two Personal Daq/56s are used in the 32-channel systems to double the acquisition speed. A [Personal Daq/56](#) contains 16 digital I/O ports, four frequency channels, and 20 analog channels. Using the IOtech [PDQ1](#)™ expansion module increases the capacity to 40 analog and 32 digital channels. The largest PatchAmp frame contains 32 amplifiers, so this is a perfect fit. Eight spare analog channels are then available for measuring power supply voltage and frame temperatures, and the four frequency channels monitor the fans' speed.

Conclusion

Numerous PatchAmp video distribution amplifiers have been in continuous use for three or four years, and none have ever failed. The [Personal Daq/56](#) system was selected because it is also highly reliable, fits the distribution amplifiers well, works easily with the software package, is small, and runs independently of the PatchAmp frame power supply.

Personal Daqs

The Personal Daqs™ are the first full-featured data acquisition products to utilize the Universal Serial Bus (USB), which is built into every new PC. Designed for high accuracy and resolution, the 22-bit Personal Daq data acquisition systems directly measure multiple channels of voltage, thermocouples, pulse, frequency, and digital I/O. A single cable to the PC provides high-speed communication *and* power to the Personal Daq. No additional batteries or power supplies are required, except when using bus-powered hubs. An AC power supply is included in the event that the PC does not provide adequate power.

Features

- Multifunction data acquisition modules attach to PCs via Universal Serial Bus (USB)
- Ultra low-power design requires no external power or batteries
- Can be located up to 5 meters (16.4 feet) from the PC
- High-resolution, 22-bit A/D converter
- Built-in cold-junction compensation for direct thermocouple measurements
- Frequency/pulse, or duty-cycle measurements up to 1 MHz
- Convenient removable screw-terminal signal connections
- 500V optical isolation from PC for safe and noise-free measurements
- Programmable inputs from ± 31 mV to ± 20 V full scale
- Digital I/O lines with open collector output for direct drive applications
- Expandable up to 80 channels of analog and digital I/O
- Up to 100 Personal Daq modules can be attached to one PC using USB hubs, for a total capacity of 8,000 channels
- Digital calibration—no potentiometers or adjustments required

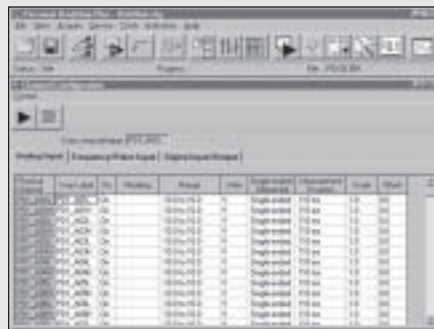
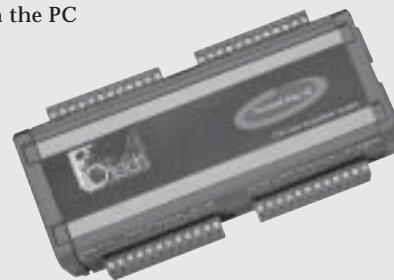

Optional Personal DaqView Plus™ provides advanced charting capabilities, including multiple traces per chart, multiple chart groups, and support for up to 100 Personal Daq devices attached to one PC. Optional Personal DaqViewXL™ allows Personal DaqView™ or Personal DaqViewXL Plus™ to seamlessly execute from within Microsoft® Excel's tool palette.

Software

Personal DaqView™ graphical data acquisition and display software is included with all Personal Daq systems. Using Personal DaqView software's spreadsheet-style interface, you can easily set up your application and begin taking data within minutes of connecting your hardware, with no programming required.

- Personal DaqView™, spreadsheet-style software for *Out-of-the-Box*™ setup, acquisition, & real-time display
- eZ-PostView™, for post-acquisition data viewing
- Drivers for Visual Basic®, Delphi™, & C++ for Windows® 98 and higher, DASyLab® & LabVIEW®

Personal Daq™, Personal DaqView™, and *Out-of-the-Box*™ are the property of IOtech; all other trademarks and tradenames are the property of their respective holders. 030106.