

# **PCI-DIO24 & PCI-DIO24H**

## **User's Guide**

Revision 3, April, 2002

© Copyright 2002, Measurement Computing Corporation

## **LIFETIME WARRANTY**

Every hardware product manufactured by Measurement Computing Corp. is warranted against defects in materials or workmanship for the life of the product, to the original purchaser. Any products found to be defective will be repaired or replaced promptly.

## **30 DAY MONEY-BACK GUARANTEE**

Any Measurement Computing Corp. product may be returned within 30 days of purchase for a full refund of the price paid for the product being returned. If you are not satisfied, or chose the wrong product by mistake, you do not have to keep it. Please call for a RMA number first. No credits or returns accepted without a copy of the original invoice. Some software products are subject to a repackaging fee.

*These warranties are in lieu of all other warranties, expressed or implied, including any implied warranty of merchantability or fitness for a particular application. The remedies provided herein are the buyer's sole and exclusive remedies. Neither Measurement Computing Corp., nor its employees shall be liable for any direct or indirect, special, incidental or consequential damage arising from the use of its products, even if Measurement Computing Corp. has been notified in advance of the possibility of such damages.*

MEGA-FIFO, the CIO prefix to data acquisition board model numbers, the PCM prefix to data acquisition board model numbers, PCM-DAS08, PCM-D24C3, PCM-DAC02, PCM-COM422, PCM-COM485, PCM-DMM, PCM-DAS16D/12, PCM-DAS16S/12, PCM-DAS16D/16, PCM-DAS16S/16, PCI-DAS6402/16, Universal Library, InstaCal, Harsh Environment Warranty and Measurement Computing Corporation are either trademarks or registered trademarks of Measurement Computing Corporation.

IBM, PC, and PC/AT are trademarks of International Business Machines Corp. Windows is a trademark of Microsoft Corp. All other trademarks are the property of their respective owners.

Information furnished by Measurement Computing Corp. is believed to be accurate and reliable. However, no responsibility is assumed by Measurement Computing Corporation neither for its use; nor for any infringements of patents or other rights of third parties, which may result from its use. No license is granted by implication or otherwise under any patent or copyrights of Measurement Computing Corporation.

All rights reserved. No part of this publication may be reproduced, stored in a retrieval system, or transmitted, in any form by any means, electronic, mechanical, by photocopying, recording or otherwise without the prior written permission of Measurement Computing Corporation.

## **Notice**

Measurement Computing Corporation does not authorize any Measurement Computing Corporation product for use in life support systems and/or devices without the written approval of the CEO of Measurement Computing Corporation. Life support devices/systems are devices or systems which, a) are intended for surgical implantation into the body, or b) support or sustain life and whose failure to perform can be reasonably expected to result in injury. Measurement Computing Corp. products are not designed with the components required, and are not subject to the testing required to ensure a level of reliability suitable for the treatment and diagnosis of people.



## Lifetime *Harsh Environment Warranty*™

Any product manufactured by Measurement Computing Corp. that is damaged (even due to misuse) may be replaced for only 50% of the current list price. I/O boards face some tough operating conditions—some more severe than the boards are designed to withstand. When a board becomes damaged, just return the unit with an order for its replacement at only 50% of the current list price. We don't need to profit from your misfortune. By the way, we honor this warranty for any manufacturer's board that we have a replacement for.



# Table of Contents

|          |   |            |
|----------|---|------------|
| <b>1</b> | <b>Introduction.....</b>                  | <b>1-1</b> |
| <b>2</b> | <b>Installation .....</b>                 | <b>2-1</b> |
| 2.1      | Installing the software.....              | 2-1        |
| 2.2      | Installing the hardware.....              | 2-1        |
| <b>3</b> | <b>I/O Connections .....</b>              | <b>3-1</b> |
| 3.1      | Cables and screw terminal boards .....    | 3-1        |
| 3.2      | Connector diagram.....                    | 3-1        |
| 3.3      | Signal connection considerations .....    | 3-2        |
| <b>4</b> | <b>Programming and applications .....</b> | <b>4-1</b> |
| 4.1      | Universal library .....                   | 4-1        |
| 4.2      | Application programs .....                | 4-1        |
| <b>5</b> | <b>Specifications.....</b>                | <b>5-1</b> |
| 5.1      | PCI-DIO24 specifications .....            | 5-1        |
| 5.2      | PCI-DIO24H specifications.....            | 5-2        |



# 1 Introduction

This manual provides installation and programming information for the PCI-DIO24 and PCI-DIO24H digital I/O boards and accessories.

The PCI-DIO24 uses an 82C55 digital I/O chip interfaced to the PCI bus, with all its 24 I/O lines accessible through the board's 37-pin connector. The I/O pins of an 82C55 are bi-directional CMOS TTL level. Refer to Figure 1-1.

PCI-DIO24H is a high drive, 24-line digital I/O board. The control register that sets the direction of the I/O ports is an emulation of the 82C55 in mode 0 (only). The 74S244 outputs are high-drive TTL, capable of sourcing 15 mA and sinking 64 mA.

This manual provides information on I/O configuration of the 82C55 in mode 0. To use the 82C55 in modes 1 or 2, refer to the PDF document [82C55A CMOS Programmable Interface at www.measurementcomputing.com/82C55](http://www.measurementcomputing.com/82C55).

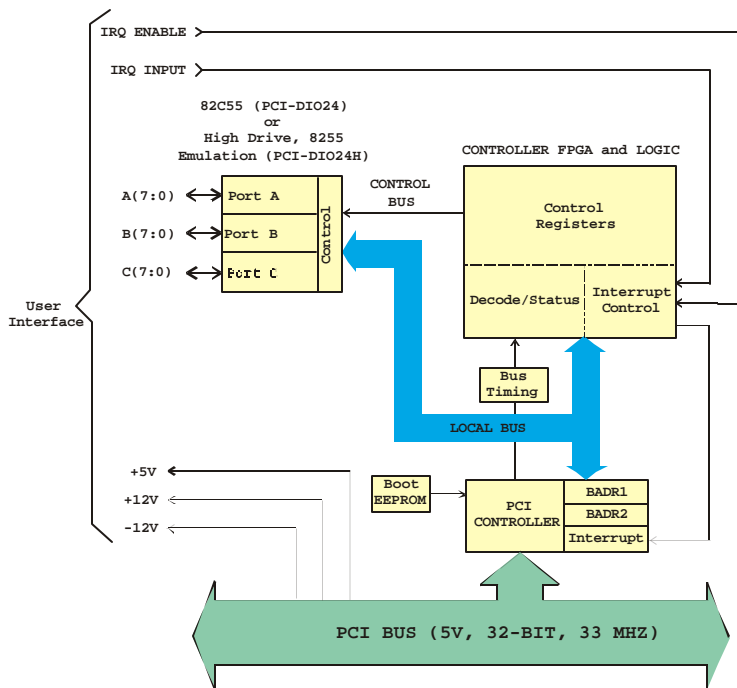

Figure 1-1 PCI-DIO24 and PCI-DIO24H Functional Block Diagram





## 2 Installation

Installing and operating the boards is very simple. Follow the procedure in this chapter to install and test your board. We assume you already know how to open the PC and install expansion boards. If you are unfamiliar or uncomfortable with board installation, please refer to your computer's documentation.

### 2.1 Installing the software

The board has no switches or jumpers to set. The simplest way to configure and test your installation is to use the *InstaCal*<sup>™</sup> program provided on the CD (or floppy disk) received with the PCI-DIO24 board.

*InstaCal* shows you any available options, and creates a configuration file that your application software (and the Universal Library<sup>™</sup>) refers to. The software you use automatically has access to the exact configuration of the board.

Refer to the *Software Installation Manual* for information on the installation and operation of *InstaCal*. This document is available on our web site at <http://www.mccdaq.com/PDFmanuals/sm-installation.pdf>.

### 2.2 Installing the hardware

The PCI-DIO24 board is completely plug-and-play. Perform the following procedure to install the hardware:

1. Turn the computer OFF, open it up, and insert the board into any available PCI slot.
2. Close up the computer and turn it ON.
3. Some operating systems, such as Windows 95 or 98, automatically detects the board as it starts up.
  - If the board's configuration file is already on the system, it loads without user interaction.
  - If the configuration file is not detected, insert the disk containing it at the prompt. The required file is on the *InstaCal* disk or CD shipped with the board. The required file(s) automatically loads, and the PCI board displays in the Device Manager under DAS components.



## 3 I/O Connections

### 3.1 Cables and screw terminal boards

The PCI-DIO24 series connector is accessible through the computer's expansion bracket. The I/O connections can be brought out to easy to use screw terminals by purchasing a C37FF-series cable and a CIO-MINI37 or CIO-TERMINAL screw terminal accessory board.

You can purchase C37FF-x series cables from <http://www.measurementcomputing.com>.

### 3.2 Connector diagram

The I/O connector is a 37-pin, male D-type connector accessible from the rear of the PC through the expansion backplate. The signals available are direct connections to the digital I/O chips as well as the PC's internal power supplies. The pinout is identical to the CIO-DIO24, except that -5VDC is not brought out (Figure 3-1).

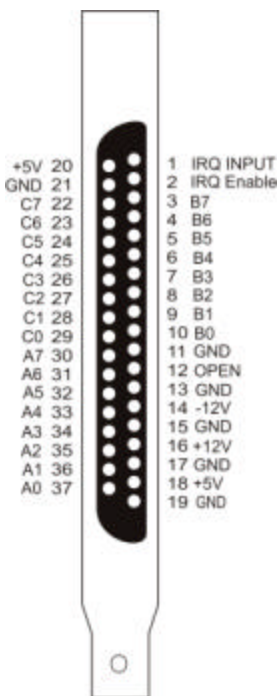

Figure 3-1. PCI-DIO24/PCI-DIO24H Series Connector Pinout

The connector accepts 37-pin, D-type female connectors such as those on the C37FF-2, which is a two-foot cable available from Measurement Computing Corp.

If you need to frequently change signal connections, or signal conditioning is required, refer to the information on the CIO-MINI37 or CIO-SPADE50 screw terminal boards.

### 3.3 Signal connection considerations

All digital outputs and inputs on the PCI-DIO24 are CMOS TTL. The PCI-DIO24H signals are buffered (high output drive) TTL. Voltages and currents associated with external devices are usually far greater than can be supplied from a PCI-DIO24 or PCI-DIO24H. Direct connections to high-current/high voltage devices will damage the board.

We offer a wide variety of digital signal conditioning products that provide an ideal interface between high voltage or high current field signals and PCI-DIO24 board. If you need to control or monitor non-TTL level signals with your board, we strongly recommend that you look in our catalog or our web site for the following products:

- CIO-ERB series, electromechanical relay output boards
- CIO-SERB series, 10A electromechanical relay output boards
- SSR-RACK series solid state I/O module racks
- DR-Series, DIN rail mountable solid state I/O modules.

Figure 3-2 shows a map of the PCI-DIO24 and PCI-DIO24H cable-to-terminal board/relay rack.

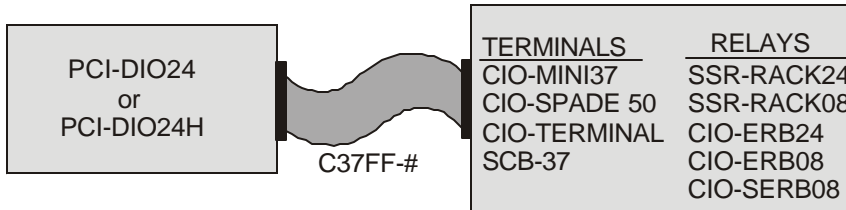

Figure 3-2. PCI-DIO24 series to Terminals/Relay racks

In addition to voltage and load matching, digital signals often need to be debounced. For general information regarding signal connection and configuration, refer to the *Guide to Signal Connections*. This document is available on our web site at <http://www.measurementcomputing.com/signals/signals.pdf>.

**Note:** The 82C55 digital I/O chip and the emulated 8255 circuit initialize all ports as inputs on power-up and reset. The state of the digital I/O lines is not defined as either logic high or logic low when in input mode. Input devices connected to the PCI-DIO24 board may detect either a high or a low and therefore may be turned off or on at power-up.

To safeguard against unwanted or signal levels, all devices being controlled by PCI-DIO24 series boards should be tied low or high as required by a 2.2K  $\Omega$  resistor. There are open positions for pull-up and pull-down resistor SIP packs on your board.

In a 2.2K, eight-resistor Single Inline Packages (SIP), one side of all resistors is connected to a single common point and brought out to a pin. The common line, usually marked with a dot or line, is at one end of the SIP. The other ends of the resistors are brought out to the other eight pins (refer to Figure 3-3).

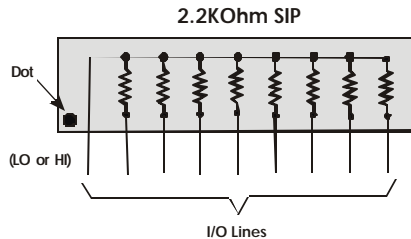
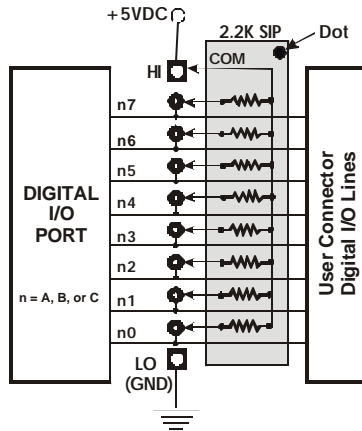
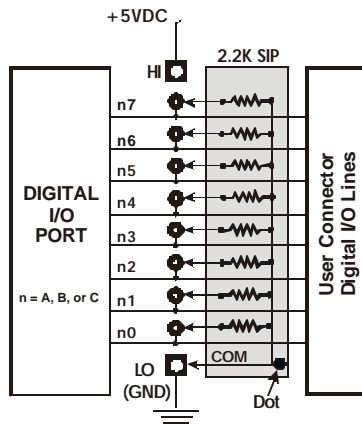

Figure 3-3. Eight-Resistor SIP Schematic



2.2K SIP INSTALLED FOR PULL-UP



2.2K SIP INSTALLED FOR PULL-DOWN

Figure 3-4. Pull-Up and Pull-Down Resistor SIPs Schematic

Figure 3-4 shows a schematic of an SIP installed in both the pull-up and pull-down positions. Open positions are located on the board to install resistor SIPs. These locations are labeled PORT A, PORT B and PORT C, and are adjacent to the 37-pin connector on the PCI-DIO24 and PCI-DIO24H.

When installed, the SIP establishes either a high or low logic level at each of the eight I/O lines on the port (Figure 3-4). At each board location, A, B, and C, there are 10 holes in a line. The hole on one end is marked "HI" and is connected to +5V. The other end is marked "LO" and is connected to GND. The eight holes in the middle connect to eight lines of the port, A, B or C.

To pull-up lines, orient the SIP with the common pin (dot) toward the HI end; to pull-down, install the resistor with the common pin in the LO hole.

**Note:** We recommend using 2.2K SIPs (Our part number is SP-K2.29C). Use a different value only if necessary.





## 4 Programming and applications

### 4.1 Universal library

The Universal Library provides complete access to the PCI-DAS08 functions from the full range of Windows<sup>®</sup> programming languages. If you are planning to write programs, or would like to run the example programs for Visual Basic<sup>™</sup> or any other language, refer now to the Universal Library manual. This document is available on our web site at <http://www.measurementcomputing.com/PDFmanuals/sm-ul-user-guide.pdf>.

### 4.2 Application programs

Many packaged application programs, such as SoftWIRE<sup>®</sup>, Labtech Notebook and HP-VEE have drivers for the PCI-DIO24 series. If your package does not have drivers for the PCI-DIO24, fax or e-mail the package name and the revision number from the install disks. We will research the package and advise you on how to obtain PCI-DIO24 drivers.

Fax: 508-946-9500 to the attention of Tech Support

Email: [techsupport@measurementcomputing.com](mailto:techsupport@measurementcomputing.com)

**Note:** Some application drivers are included with the Universal Library package, but not with the application package. If you purchased an application package directly from the software vendor, you may need to purchase our Universal Library and drivers. For more information, contact us at [info@measurementcomputing.com](mailto:info@measurementcomputing.com).



## 5 Specifications

### 5.1 PCI-DIO24 specifications

#### Power consumption

|               |                            |
|---------------|----------------------------|
| +5V Operating | 240 mA typical, 350 mA max |
|---------------|----------------------------|

#### Digital Input / Output

|                        |  |
|------------------------|--|
| Digital Type           | 82C55  |
| Configuration          | 2 banks of 8, 2 banks of 4, programmable by bank as input or output  |
| Number of channels     | 24 I/O   |
| Output High            | 3.7 volts min @ -2.5 mA  |
| Output Low             | 0.4 volts max @ 2.5 mA   |
| Input High             | 2.2 volts min, 5.3 volts absolute max  |
| Input Low              | 0.8 volts max, -0.3 volts absolute min   |
| Power-up / reset state | Input mode (high impedance)  |
| Interrupts             | INTA# - mapped to IRQn via PCI BIOS at boot-time   |
| Interrupt enable       | External (IR ENABLE, active low, disabled by default through internal resistor to TTL high) and programmable through PCI9052.<br>0 = disabled<br>1 = enabled (default) |
| Interrupt sources      | External source (IR INPUT), polarity programmable through PCI9052.<br>1 = active high<br>0 = active low (default)  |

#### Environmental

|                             |                         |
|-----------------------------|-------------------------|
| Operating temperature range | 0 to 50 °C              |
| Storage temperature range   | -20 to 70 °C            |
| Humidity                    | 0 to 90% non-condensing |

## 5.2 PCI-DIO24H specifications

### Power consumption

|               |                            |
|---------------|----------------------------|
| +5V Operating | 625 mA typical, 960 mA max |
|---------------|----------------------------|

### Digital Input / Output

|                        |  |
|------------------------|--|
| Digital Type           | 8255 mode 0 emulation  |
| Output:                | 74S244   |
| Input:                 | 74LS373  |
| Configuration          | 2 banks of 8, 2 banks of 4, programmable by bank as input or output  |
| Number of channels     | 24 I/O   |
| Output High            | 2.4 volts min @ -15mA  |
| Output Low             | 0.5 volts max @ 64 mA  |
| Input High             | 2.0 volts min, 7 volts absolute max  |
| Input Low              | 0.8 volts max, -0.5 volts absolute min   |
| Power-up / reset state | Input mode (high impedance)  |
| Interrupts             | INTA# - mapped to IRQn via PCI BIOS at boot-time   |
| Interrupt enable       | External (IR ENABLE, active low, disabled by default through internal resistor to TTL high) and programmable through PCI9052.<br>0 = disabled<br>1 = enabled (default) |
| Interrupt sources      | External source (IR INPUT), polarity programmable through PCI9052.<br>1 = active high<br>0 = active low (default)  |

### Environmental

|                             |                         |
|-----------------------------|-------------------------|
| Operating temperature range | 0 to 50 °C              |
| Storage temperature range   | -20 to 70 °C            |
| Humidity                    | 0 to 90% non-condensing |

# EC Declaration of Conformity

We, Measurement Computing Corporation, declare under sole responsibility that the product

|            |  |
|------------|--|
| PCI-DIO24  | 24-bit digital I/O for PCI bus                   |
| PCI-DIO24H | 24-bit high output drive digital I/O for PCI bus |

---

*Part Number*

*Description*

to which this declaration relates, meets the essential requirements, is in conformity with, and CE marking has been applied according to the relevant EC Directives listed below using the relevant section of the following EC standards and other informative documents:

- EU EMC Directive 89/336/EEC: Essential requirements relating to electromagnetic compatibility.
- EN 55022 Class B (1995): Radiated and conducted emission requirements for information technology equipment.
- ENV 50204 (1995): Radio-frequency electromagnetic field immunity.
- EN 55024 (1998): EC generic immunity requirements.
- EN50082-1 (1997): EC generic immunity requirements.
- EN 61000-4-2 (1995): Electrostatic discharge immunity.
- EN 61000-4-3 (1997) ENV 50204 (1996): RF immunity.
- EN 61000-4-4 (1995): Electric fast transient burst immunity.
- EN 61000-4-5 (1995): Surge immunity.
- EN 61000-4-6 (1996): Radio frequency common mode immunity.
- EN 61000-4-8 (1994): Power frequency magnetic field immunity.
- EN 61000-4-11 (1994): Voltage dip and interrupt immunity.

Carl Haapaoja, Vice-President of Design Verification

**Measurement Computing Corporation**  
**16 Commerce Boulevard,**  
**Middleboro, Massachusetts 02346**  
**(508) 946-5100**  
**Fax: (508) 946-9500**  
**E-mail: [info@measurementcomputing.com](mailto:info@measurementcomputing.com)**  
**[www.measurementcomputing.com](http://www.measurementcomputing.com)**